

## Datasheet

### SFP+ Optical Transceiver Product Features

- 10GBASE-ER/EW Ethernet 14dB SFP+
- 40 km ER SFP+ for SMF @ 10Gbps
- 100GHz (C-Band) EML+PIN Laser 40 km SFP+
- 0°C - 70°C Temperature - Extended/Industrial Available
- 2-Wire Interface Digital Diagnostic Monitoring (SFF-8724)
- Hot-swappable for SFP+ LC ports
- OptoSpan 1 year standard warranty
- Use with Finisar, Avago, JDSU & networks not requiring OEM compatibility
- Compliant with SFF-8431, SFF-8432
- RoHS compliant

\* For OEM Compatibility, use Platinum Series Part# PSPP-81DDXXK040

### SPP-81D-K040DXX



### Applications

- 10GBASE-ER @ 10.31Gbps
- 10 Gigabit Ethernet
- Fibre Channel 8x
- Fibre Channel 4x

### Description

OptoSpan SPP-81D-K040DXX is a DWDM 10GBASE-ER/EW Ethernet 10G Ethernet / 8G FC SFP+ transceiver designed for long distance optical communications up to 40 km with signaling rates up to 10Gbps.

OptoSpan 10Gb DWDM optical transceivers are compatible with many brands such as Finisar, Avago, JDSU and network environments that do not require any special compatibility. For networks that require special OEM compatibility, such as CISCO, BROCADE, JUNIPER, ALCATEL, HP, NORTEL, EMC, QLOGIC and other OEMs, consider OptoSpan Platinum OEM Series transceiver model# PSPP-81DDXXK040.

All OptoSpan long-reach SFP+ s are ROHS compliant, allow for real-time diagnostic monitoring as per SFF-8472 and designed to meet Multi-Source Agreement (MSA) standards for DWDM transceivers with LC interface.

### Optical Budget Calculation for 40 km SFP+ Optical Transceiver

SPP-81D-K040DXX	Distance: 40 km				Fiber: 100GHz (C-Band) SMF	
	Tx Min dBm	Tx Max dBm	Rx Min dBm	Rx Max dBm	Link Attenuation dB	Power Budget dB
Product Specifications	-1	4	-15	-1		
Optical Calculation Results			-15.8	-10.8	13.8	14



SFP+ DWDM 40 km transceiver | 10G ER Ethernet

## General Specifications

Parameter	Unit	Min.	Typ.	Max
<b>Absolute Maximum Ratings</b>				
Maximum Supply Voltage	V	-0.5		3.6
Storage Temperature	°C	-40		85
Case Operating Temperature	°C	0		70
<b>Recommended Operating Condition</b>				
Supply Voltage	V	3.15	3.3	3.45
Supply Current	mA		350	455
Data Rate	Gbps	9.953		11.1

## Electrical Characteristics

Parameter	Unit	Min.	Typ.	Max
<b>Transmitter</b>				
Differential Input Voltage Swing	mVpp	250		1000
Input Differential Impedance	ohm	85	100	115
Transmit Disable Voltage - High	V	2		Vcc+0.3
Transmit Disable Voltage - Low	V	0		0.8
Transmit Fault Voltage - High	V	2		Vcc+0.3
Transmit Fault Voltage - Low	V	0		0.5
<b>Receiver</b>				
Differential Output Voltage Swing	mVpp	350		700
Differential Output Impedance	ohms	85	100	115
LOS Output Voltage - High	V	2		Vcc+0.3
LOS Output Voltage - Low	V	0		0.8

## Optical Characteristics

Parameter	Unit	Min.	Typ.	Max
<b>Transmitter</b>				
Output Optical Power	dBm	-1		4
Optical Extinction Ratio	dB	3.5		
Optical Wavelength	nm			
Spectral Width	nm			
Side Mode Suppression Ratio	dB	30		
<b>Receiver</b>				
Optical Center Wavelength	nm			
Receiver Sensitivity @ 10.3Gbps	dBm	-15		-1
LOS DE-Assert	dBm			-17
LOS Assert	dBm	-29		

## Laser Safety

This is a class 1 Laser Product according to IEC 60825-1:1993:+A1:1997+A2:2001. This product complies with 21 CFR 1040.10 and 1040 except for deviations pursuant to Laser Notice No. 50, dated July 26, 2001.

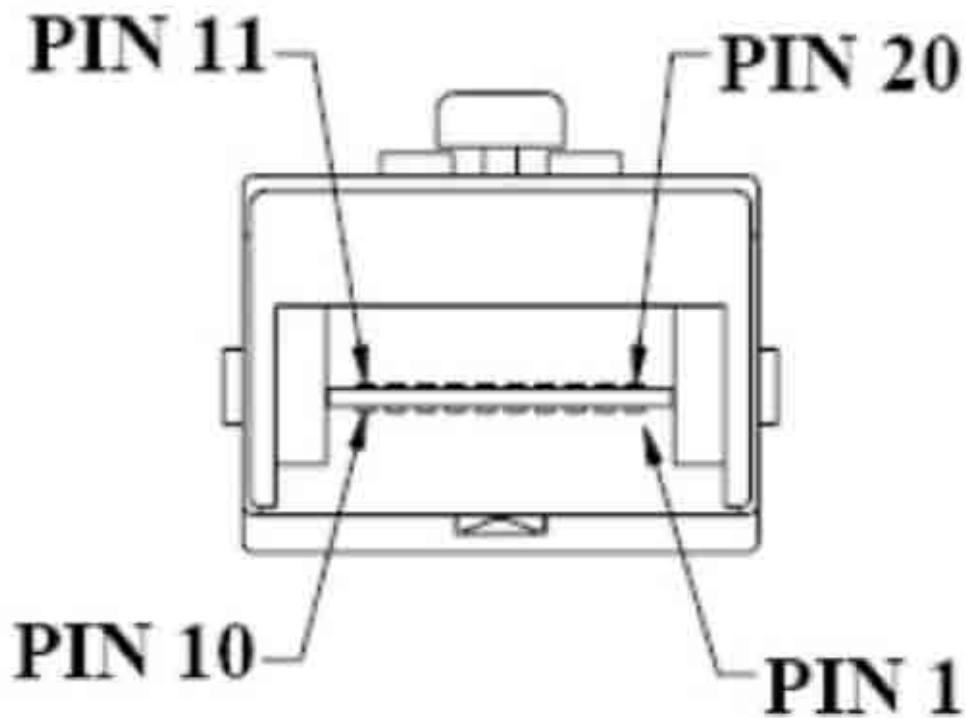
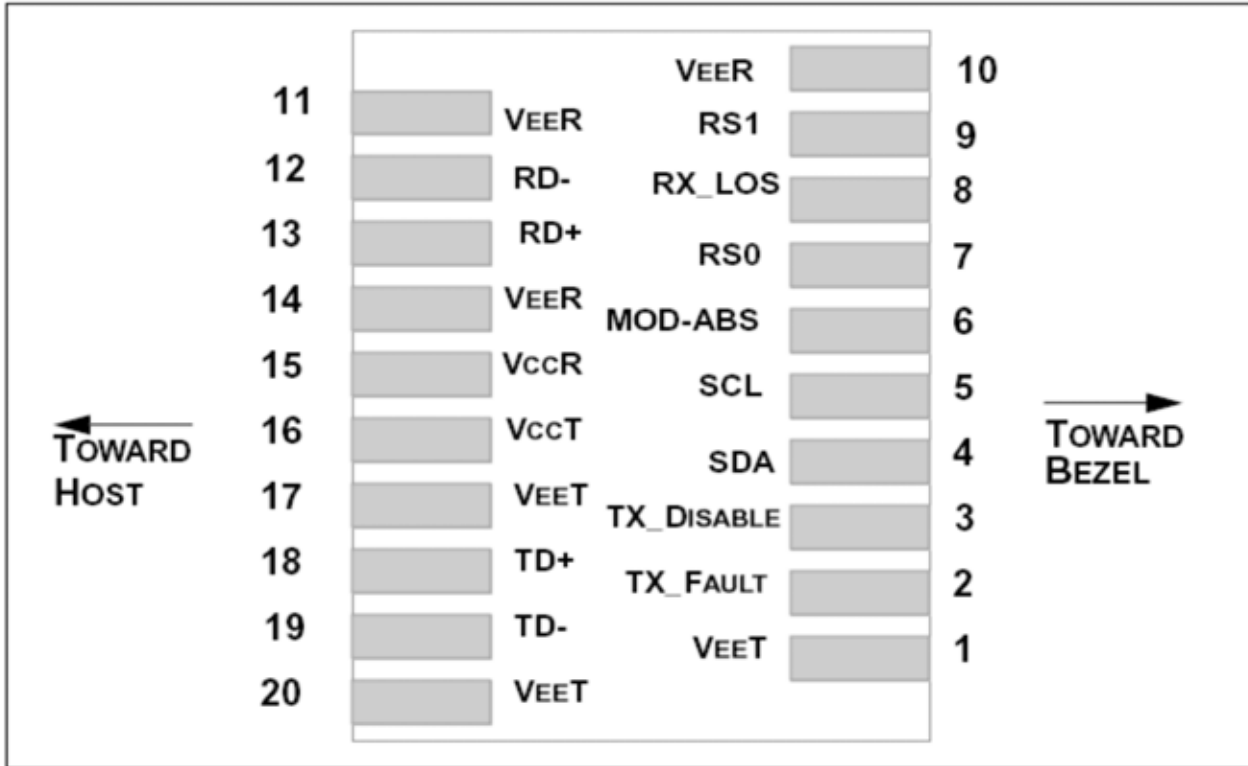



**SFP+ DWDM 40 km transceiver | 10G ER Ethernet**  
**PIN Functions**

Pin #	Name - Description
1	Transmitter Ground
2	Transmitter Fault Indication
3	Transmitter Disable
4	Module Definition 2
5	Module Definition 1
6	Module Definition 0
7	RX Rate Select (LVTTL)
8	Loss of Signal
9	TX Rate Select (LVTTL)
10	Receiver Ground
11	Receiver Ground
12	Inv. Received Data Out
13	Received Data Out
14	Receiver Ground
15	Receiver Power
16	Transmitter Power
17	Transmitter Ground
18	Transmit Data In
19	Inv. Transmit Data In
20	Transmitter Ground
21	
22	
23	
24	
25	
26	
27	
28	
29	
30	

## SFP+ DWDM 40 km transceiver | 10G ER Ethernet Mechanical Layouts

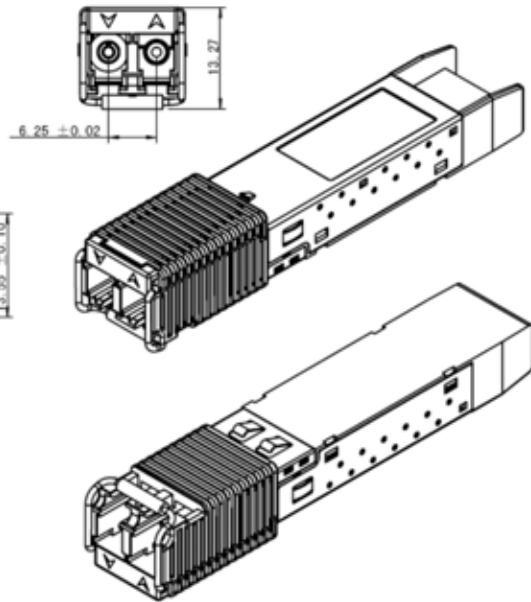
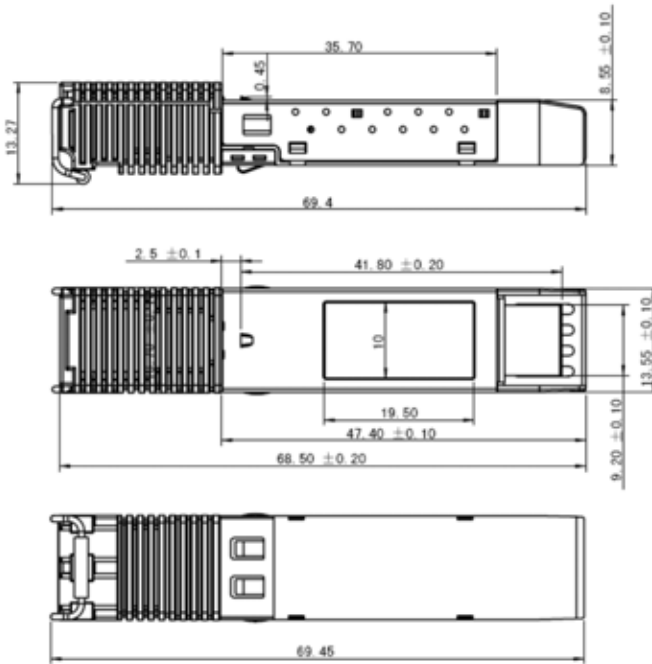
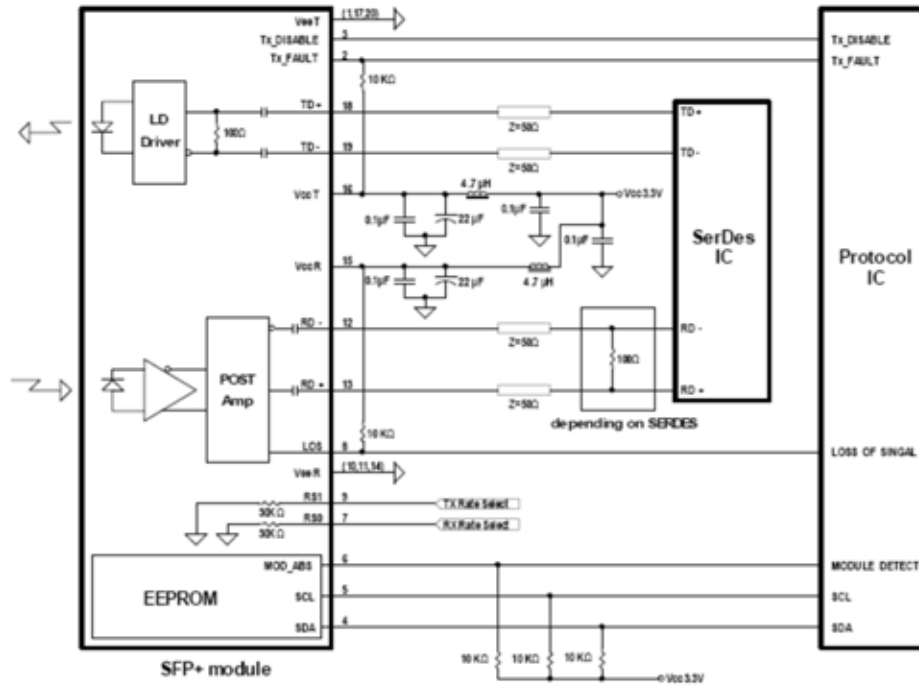

OptoSpan reserves the right to make changes or to discontinue any optical product or service without any notice. Applications and features described herein are for illustrative purposes only. OptoSpan makes no representation of warranty that such applications or features will be suitable for any specific use or compatibility without further testing or modifications. Not responsible for typographical errors.