

## Datasheet

### X2 Optical Transceiver Product Features

- 10GBASE-ER/EW Ethernet 13.1dB X2
- 40 km ER X2 for SMF @ 10Gbps
- 1550nm EML+PIN Laser 40 km X2
- 0°C - 70°C Temperature - Extended/Industrial Available
- 2-Wire Interface Digital Diagnostic Monitoring (SFF-8724)
- Hot-swappable for X2 LC ports
- OptoSpan 1 year standard warranty
- Use with Finisar, Avago, JDSU & networks not requiring OEM compatibility
- X2 MSA / IEEE 802.3ae/q/k
- RoHS compliant

\* For OEM Compatibility, use Platinum Series Part# PX2T-10GT55K040

### X2T-10G-K040T55



### Applications

- 10 Gigabit Ethernet
- 10GBASE-ER @ 10.31Gbps
- Other Optical Links

### Description

OptoSpan X2T-10G-K040T55 is a Duplex 10GBASE-ER/EW Ethernet X2 transceiver designed for long distance optical communications up to 40 km with signaling rates up to 10Gbps.

OptoSpan 10Gb Standard optical transceivers are compatible with many brands such as Finisar, Avago, JDSU and network environments that do not require any special compatibility. For networks that require special OEM compatibility, such as CISCO, BROCADE, JUNIPER, ALCATEL, HP, NORTEL, EMC, QLOGIC and other OEMs, consider OptoSpan Platinum OEM Series transceiver model# PX2T-10GT55K040.

All OptoSpan long-reach X2 s are ROHS compliant, allow for real-time diagnostic monitoring as per SFF-8472 and designed to meet Multi-Source Agreement (MSA) standards for Duplex transceivers with LC interface.

### Optical Budget Calculation for 40 km X2 Optical Transceiver

X2T- 10G- K040T55	Distance: 40 km				Fiber: 1550nm SMF	
	Tx Min dBm	Tx Max dBm	Rx Min dBm	Rx Max dBm	Link Attenuation dB	Power Budget dB
Product Specifications	-1	2	-14.1	0.5		
Optical Calculation Results			-13.2	-10.2	12.2	13.1



X2 40 km transceiver | 10G ER Ethernet

### General Specifications

Parameter	Unit	Min.	Typ.	Max
<b>Absolute Maximum Ratings</b>				
Maximum Supply Voltage	V	-0.3		4.0
Storage Temperature	°C	-40		+85
Case Operating Temperature	°C	-5		+70
<b>Recommended Operating Condition</b>				
Supply Voltage	V	3.13	3.3	3.47
Supply Current	mA			300
Data Rate	Gbps		10.31	

### Electrical Characteristics

Parameter	Unit	Min.	Typ.	Max
<b>Transmitter</b>				
Differential Input Voltage Swing	mVpp	175		2000
Input Differential Impedance	ohm	80	100	120
Transmit Disable Voltage - High	V			
Transmit Disable Voltage - Low	V			
Transmit Fault Voltage - High	V			
Transmit Fault Voltage - Low	V			
<b>Receiver</b>				
Differential Output Voltage Swing	mVpp	800		1600
Differential Output Impedance	ohms	80	100	120
LOS Output Voltage - High	V			
LOS Output Voltage - Low	V			

## Optical Characteristics

Parameter	Unit	Min.	Typ.	Max
<b>Transmitter</b>				
Output Optical Power	dBm	-1		2
Optical Extinction Ratio	dB		8.2	
Optical Wavelength	nm	1530	1550	1570
Spectral Width	nm		0.6	
Side Mode Suppression Ratio	dB	30		
<b>Receiver</b>				
Optical Center Wavelength	nm	1260		1600
Receiver Sensitivity @ 10.31Gbp	dBm	-14.1		0.5
LOS DE-Assert	dBm			
LOS Assert	dBm			

## Laser Safety

This is a class 1 Laser Product according to IEC 60825-1:1993:+A1:1997+A2:2001. This product complies with 21 CFR 1040.10 and 1040 except for deviations pursuant to Laser Notice No. 50, dated July 26, 2001.

## PIN Layout

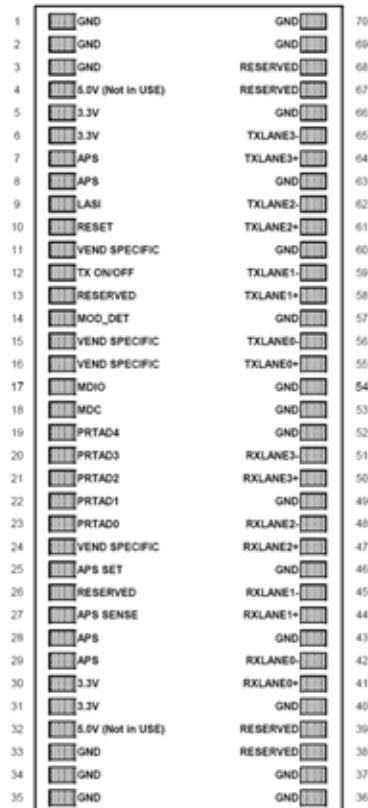
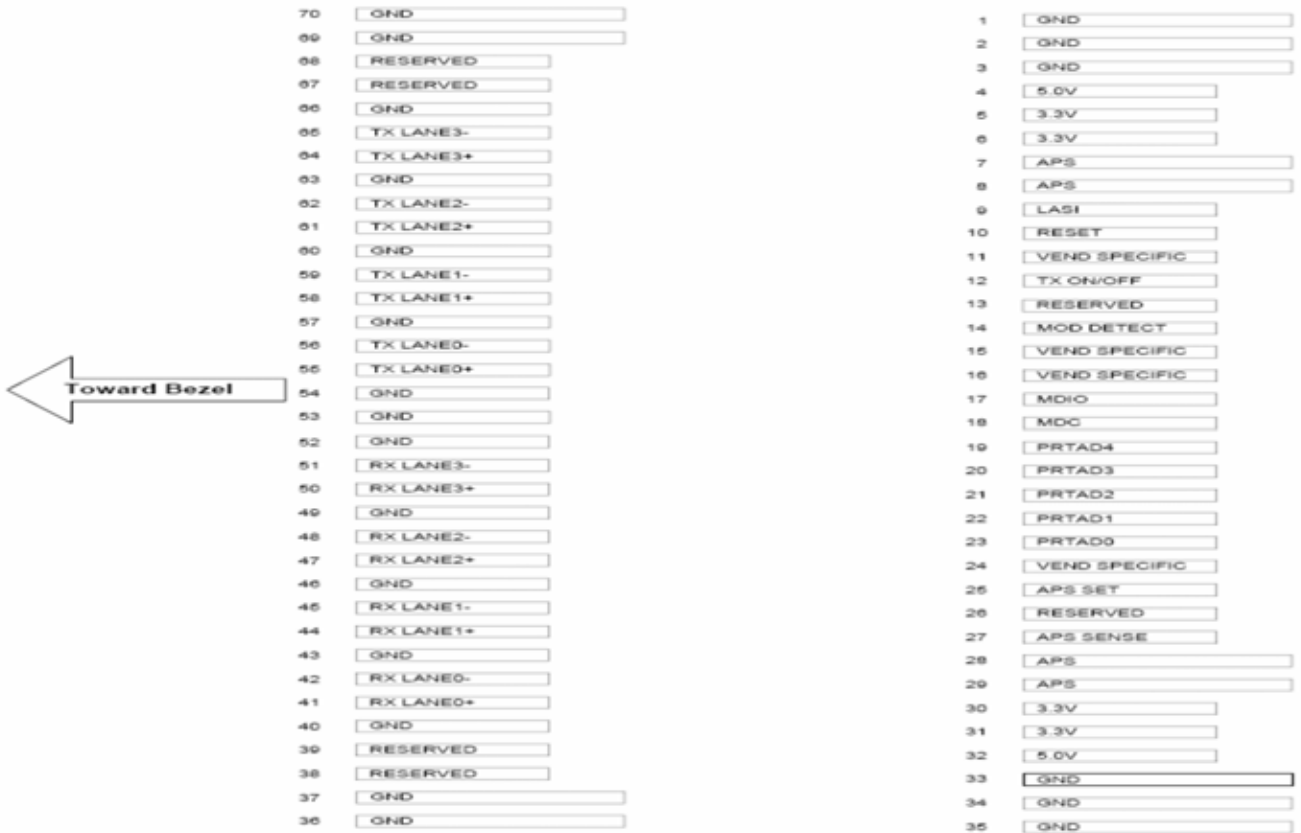



X2 40 km transceiver | 10G ER Ethernet

## PIN Functions

Pin #	Name - Description
1	Electrical Ground
2	Electrical Ground
3	Electrical Ground
4	Power
5	Power
6	Power
7	Adaptive Power Supply
8	Adaptive Power Supply
9	Open Drain Compatible 10K-22K pull up on host
10	Open Drain compatible.10-22K pull-up on transceiver
11	Vendor Specific Pin. Leave unconnected when not in use
12	Open Drain compatible. 10-22K pull-up on transceiver
13	Reserved
14	Pulled low inside module through 1k
15	Vendor Specific Pin.Leave unconnected when not in use
16	Vendor Specific Pin.Leave unconnected when not in use
17	Management Data IO
18	Management Data Clock
19	Port Address Bit 4 (Low = 0)
20	Port Address Bit 3 (Low = 0)
21	Port Address Bit 2(Low = 0)
22	Port Address Bit 3(Low = 0)
23	Port Address Bit 0 (Low = 0)
24	Vendor Specific Pin.Leave unconnected when not in use
25	Feedback input for APS
26	Reserved for Avalanche Photodiode use
27	APS Sense Connection
28	Adaptive Power Supply
29	Adaptive Power Supply
30	Power

## Mechanical Layouts

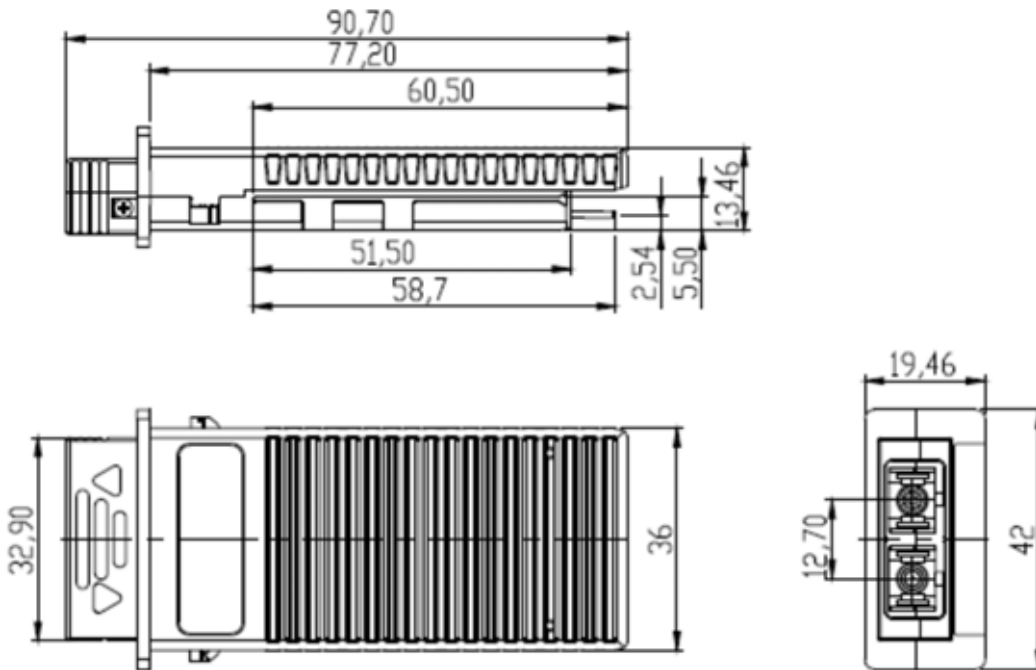
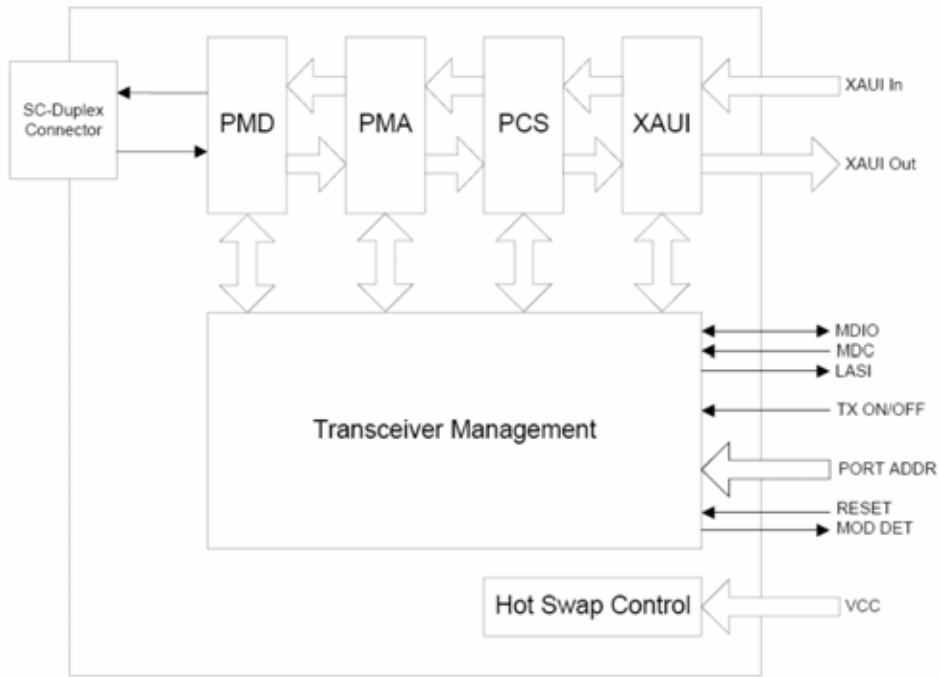

OptoSpan reserves the right to make changes or to discontinue any optical product or service without any notice. Applications and features described herein are for illustrative purposes only. OptoSpan makes no representation of warranty that such applications or features will be suitable for any specific use or compatibility without further testing or modifications. Not responsible for typographical errors.