

Datasheet

XENPAK Optical Transceiver Product Features

- 10GBASE-LR/LW Ethernet 8.4dB XENPAK
- 10 km LR XENPAK for SMF @ 10Gbps
- 1310nm DFB+PIN Laser 10 km XENPAK
- 0°C - 70°C Temperature - Extended/Industrial Available
- 2-Wire Interface Digital Diagnostic Monitoring (SFF-8724)
- Hot-swappable for XENPAK LC ports
- OptoSpan 1 year standard warranty
- Use with Finisar, Avago, JDSU & networks not requiring OEM compatibility
- XENPAK MSA / IEEE 802.3ae/q/k
- RoHS compliant

* For OEM Compatibility, use Platinum Series Part# PXEN-10GT31K010

XEN-10G-K010T31



Applications

- 10 Gigabit Ethernet
- 10GBASE-LR @ 10.31Gbps
- 10GBASE-LW @ 9.95Gbps
- Other Optical Links

Description

OptoSpan XEN-10G-K010T31 is a Duplex 10GBASE-LR/LW Ethernet XENPAK transceiver designed for long distance optical communications up to 10 km with signaling rates up to 10Gbps.

OptoSpan 10Gb Standard optical transceivers are compatible with many brands such as Finisar, Avago, JDSU and network environments that do not require any special compatibility. For networks that require special OEM compatibility, such as CISCO, BROCADE, JUNIPER, ALCATEL, HP, NORTEL, EMC, QLOGIC and other OEMs, consider OptoSpan Platinum OEM Series transceiver model# PXEN-10GT31K010.

All OptoSpan long-reach XENPAK s are ROHS compliant, allow for real-time diagnostic monitoring as per SFF-8472 and designed to meet Multi-Source Agreement (MSA) standards for Duplex transceivers with LC interface.

Optical Budget Calculation for 10 km XENPAK Optical Transceiver

XEN- 10G-K010T31	Distance: 10 km				Fiber: 1310nm SMF	
	Tx Min dBm	Tx Max dBm	Rx Min dBm	Rx Max dBm	Link Attenuation dB	Power Budget dB
Product Specifications	-6	0	-14.4	0.5		
Optical Calculation Results			-11.5	-5.5	5.5	8.4



XENPAK 10 km transceiver | 10G LR Ethernet

General Specifications

Parameter	Unit	Min.	Typ.	Max
Absolute Maximum Ratings				
Maximum Supply Voltage	V	-0.5		3.6
Storage Temperature	°C	-40		+85
Case Operating Temperature	°C	-5		+70
Recommended Operating Condition				
Supply Voltage	V	3.15	3.3	3.45
Supply Current	mA			300
Data Rate	Gbps			10.31

Electrical Characteristics

Parameter	Unit	Min.	Typ.	Max
Transmitter				
Differential Input Voltage Swing	mVpp	150		1200
Input Differential Impedance	ohm	85	100	115
Transmit Disable Voltage - High	V	2		3.45
Transmit Disable Voltage - Low	V	0		0.8
Transmit Fault Voltage - High	V	2		Vcc+0.3
Transmit Fault Voltage - Low	V	0		0.8
Receiver				
Differential Output Voltage Swing	mVpp	350		700
Differential Output Impedance	ohms	90	100	110
LOS Output Voltage - High	V	2		Vcc+0.3
LOS Output Voltage - Low	V	0		0.8

Optical Characteristics

Parameter	Unit	Min.	Typ.	Max
Transmitter				
Output Optical Power	dBm	-6		0
Optical Extinction Ratio	dB	3.5		
Optical Wavelength	nm	1270	1310	1355
Spectral Width	nm			1
Side Mode Suppression Ratio	dB	30		
Receiver				
Optical Center Wavelength	nm	1260		1565
Receiver Sensitivity @ 10.31Gbp	dBm	-14.4		0.5
LOS DE-Assert	dBm			-15
LOS Assert	dBm	-25		

Laser Safety

This is a class 1 Laser Product according to IEC 60825-1:1993:+A1:1997+A2:2001. This product complies with 21 CFR 1040.10 and 1040 except for deviations pursuant to Laser Notice No. 50, dated July 26, 2001.

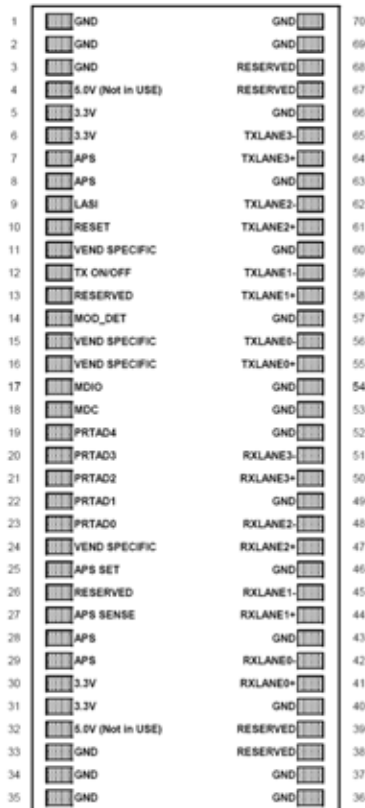
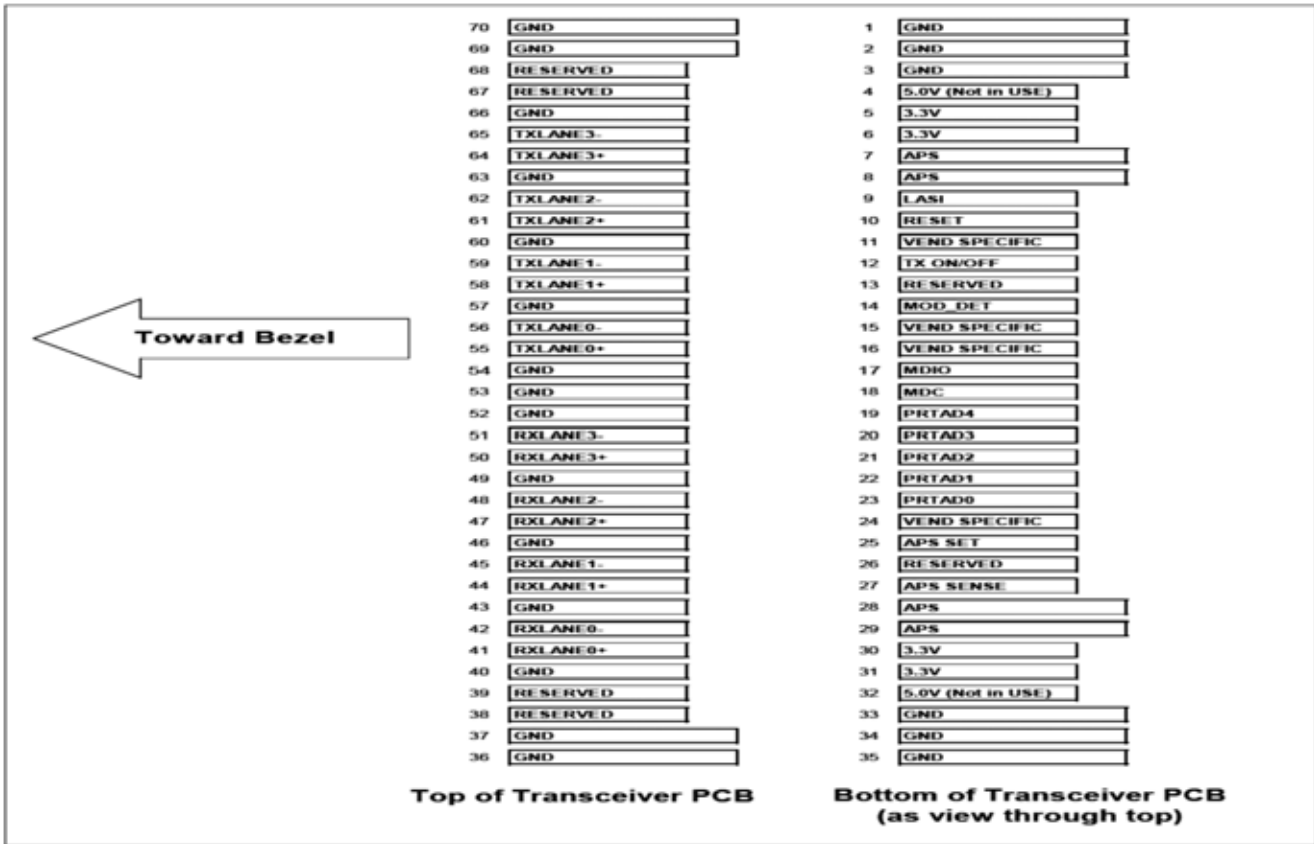



XENPAK 10 km transceiver | 10G LR Ethernet

PIN Functions

Pin #	Name - Description
1	Electrical Ground
2	Electrical Ground
3	Electrical Ground
4	Power
5	Power
6	Power
7	Adaptive Power Supply
8	Adaptive Power Supply
9	Open Drain Compatible.10K-22K pull up on host
10	Open Drain compatible.10-22K pull-up on transceiver
11	Vendor Specific Pin.Leave unconnected when not in use
12	Open Drain compatible.10-22K pull-up on transceiver
13	Reserved
14	Pulled low inside module through 1k
15	Vendor Specific Pin.Leave unconnected when not in use
16	Vendor Specific Pin.Leave unconnected when not in use
17	Management Data IO
18	Management Data Clock
19	Port Address Bit 4 (Low = 0)
20	Port Address Bit 3 (Low = 0)
21	Port Address Bit 2 (Low = 0)
22	Port Address Bit 1 (Low = 0)
23	Port Address Bit 0 (Low = 0)
24	Vendor Specific Pin.Leave unconnected when not in use
25	Feedback input for APS
26	Reserved for Avalanche Photodiode use
27	APS Sense Connection
28	Adaptive Power Supply
29	Adaptive Power Supply
30	Power

Mechanical Layouts

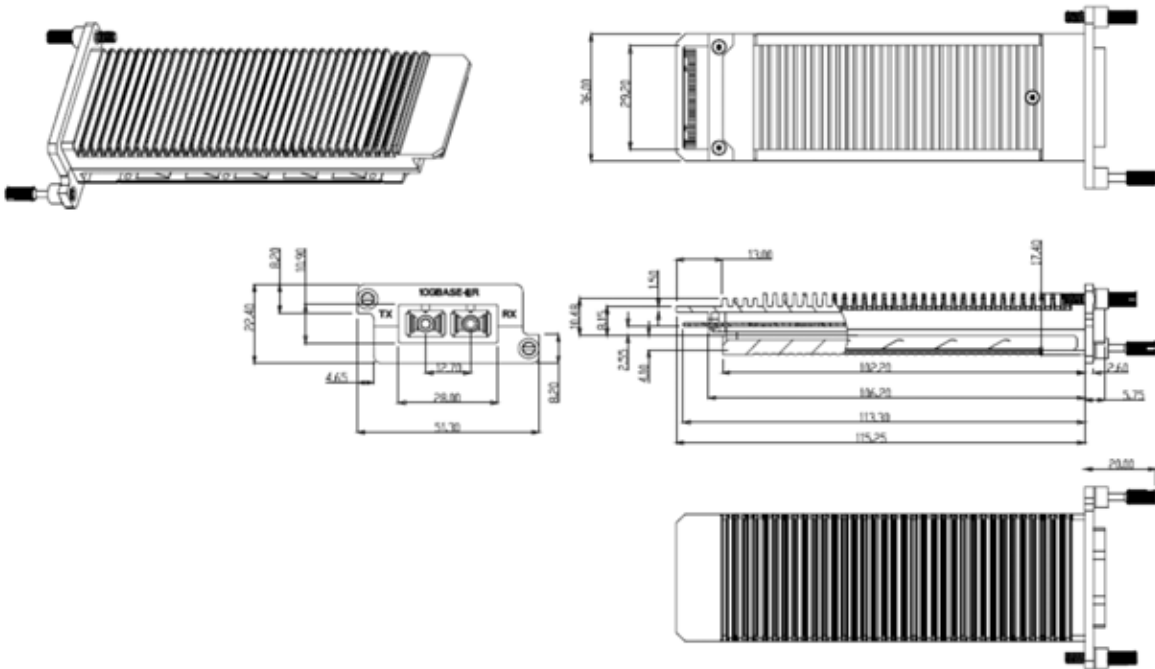
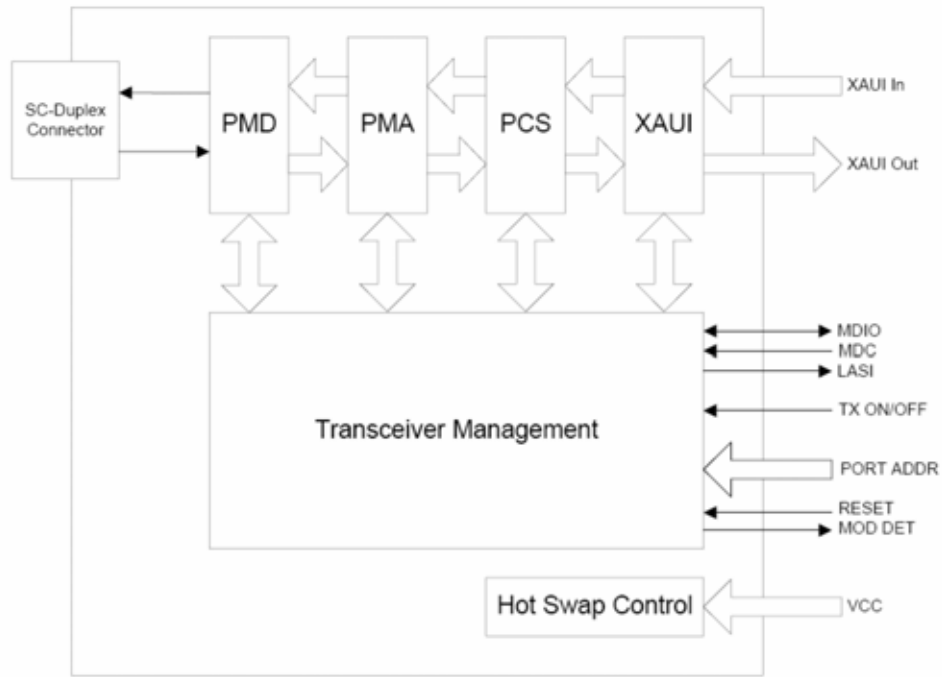

OptoSpan reserves the right to make changes or to discontinue any optical product or service without any notice. Applications and features described herein are for illustrative purposes only. OptoSpan makes no representation of warranty that such applications or features will be suitable for any specific use or compatibility without further testing or modifications. Not responsible for typographical errors.