

## Datasheet

### XENPAK Optical Transceiver Product Features

- 10GBASE-SR/SW Ethernet 5.1dB XENPAK
- 300m SR XENPAK for MMF @ 10Gbps
- 850nm VCSEL+PIN Laser 300m XENPAK
- 0°C - 70°C Temperature - Extended/Industrial Available
- 2-Wire Interface Digital Diagnostic Monitoring (SFF-8724)
- Hot-swappable for XENPAK LC ports
- OptoSpan 1 year standard warranty
- Use with Finisar, Avago, JDSU & networks not requiring OEM compatibility
- XENPAK MSA / IEEE 802.3ae/q/k
- RoHS compliant

\* For OEM Compatibility, use Platinum Series Part# PXEN-10GT85M300

### XEN-10G-M300T85



### Applications

- 10 Gigabit Ethernet
- 10GBASE-SR @ 10.31Gbps
- 10GBASE-SW @ 9.95Gbps
- Other Optical Links

### Description

OptoSpan XEN-10G-M300T85 is a Duplex 10GBASE-SR/SW Ethernet XENPAK transceiver designed for long distance optical communications up to 300m with signaling rates up to 10Gbps.

OptoSpan 10Gb Standard optical transceivers are compatible with many brands such as Finisar, Avago, JDSU and network environments that do not require any special compatibility. For networks that require special OEM compatibility, such as CISCO, BROCADE, JUNIPER, ALCATEL, HP, NORTEL, EMC, QLOGIC and other OEMs, consider OptoSpan Platinum OEM Series transceiver model# PXEN-10GT85M300.

All OptoSpan long-reach XENPAK s are ROHS compliant, allow for real-time diagnostic monitoring as per SFF-8472 and designed to meet Multi-Source Agreement (MSA) standards for Duplex transceivers with LC interface.

### Optical Budget Calculation for 300m XENPAK Optical Transceiver

XEN- 10G-M300T85	Distance: 300m				Fiber: 850nm MMF	
	Tx Min dBm	Tx Max dBm	Rx Min dBm	Rx Max dBm	Link Attenuation dB	Power Budget dB
Product Specifications	-6	-1	-11.1	-1		
Optical Calculation Results			-7.99	-2.99	1.99	5.1



XENPAK 300m transceiver | 10G SR Ethernet

### General Specifications

Parameter	Unit	Min.	Typ.	Max
<b>Absolute Maximum Ratings</b>				
Maximum Supply Voltage	V	-0.5		3.6
Storage Temperature	°C	-40		+85
Case Operating Temperature	°C	0		+70
<b>Recommended Operating Condition</b>				
Supply Voltage	V	3.15	3.3	3.45
Supply Current	mA			300
Data Rate	Gbps			10.31

### Electrical Characteristics

Parameter	Unit	Min.	Typ.	Max
<b>Transmitter</b>				
Differential Input Voltage Swing	mVpp	150		1200
Input Differential Impedance	ohm	85	100	115
Transmit Disable Voltage - High	V	2		Vcc+0.3
Transmit Disable Voltage - Low	V	0		0.8
Transmit Fault Voltage - High	V	2		Vcc+0.3
Transmit Fault Voltage - Low	V	0		0.8
<b>Receiver</b>				
Differential Output Voltage Swing	mVpp	350		700
Differential Output Impedance	ohms	85	100	115
LOS Output Voltage - High	V	2		Vcc+0.3
LOS Output Voltage - Low	V	0		0.8



XENPAK 300m transceiver | 10G SR Ethernet

## Optical Characteristics

Parameter	Unit	Min.	Typ.	Max
<b>Transmitter</b>				
Output Optical Power	dBm	-6		-1
Optical Extinction Ratio	dB	3.0	5.0	
Optical Wavelength	nm	840	850	860
Spectral Width	nm			0.45
Side Mode Suppression Ratio	dB			
<b>Receiver</b>				
Optical Center Wavelength	nm	840	850	860
Receiver Sensitivity @ 10Gbps	dBm	-11.1		-1
LOS DE-Assert	dBm			-13
LOS Assert	dBm	-25		

## Laser Safety

This is a class 1 Laser Product according to IEC 60825-1:1993:+A1:1997+A2:2001. This product complies with 21 CFR 1040.10 and 1040 except for deviations pursuant to Laser Notice No. 50, dated July 26, 2001.

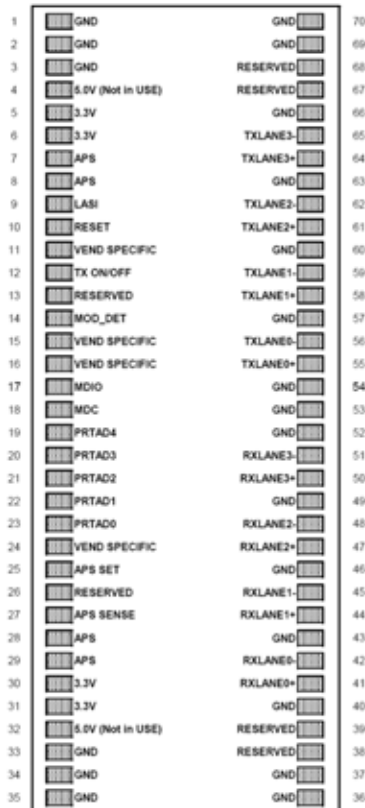
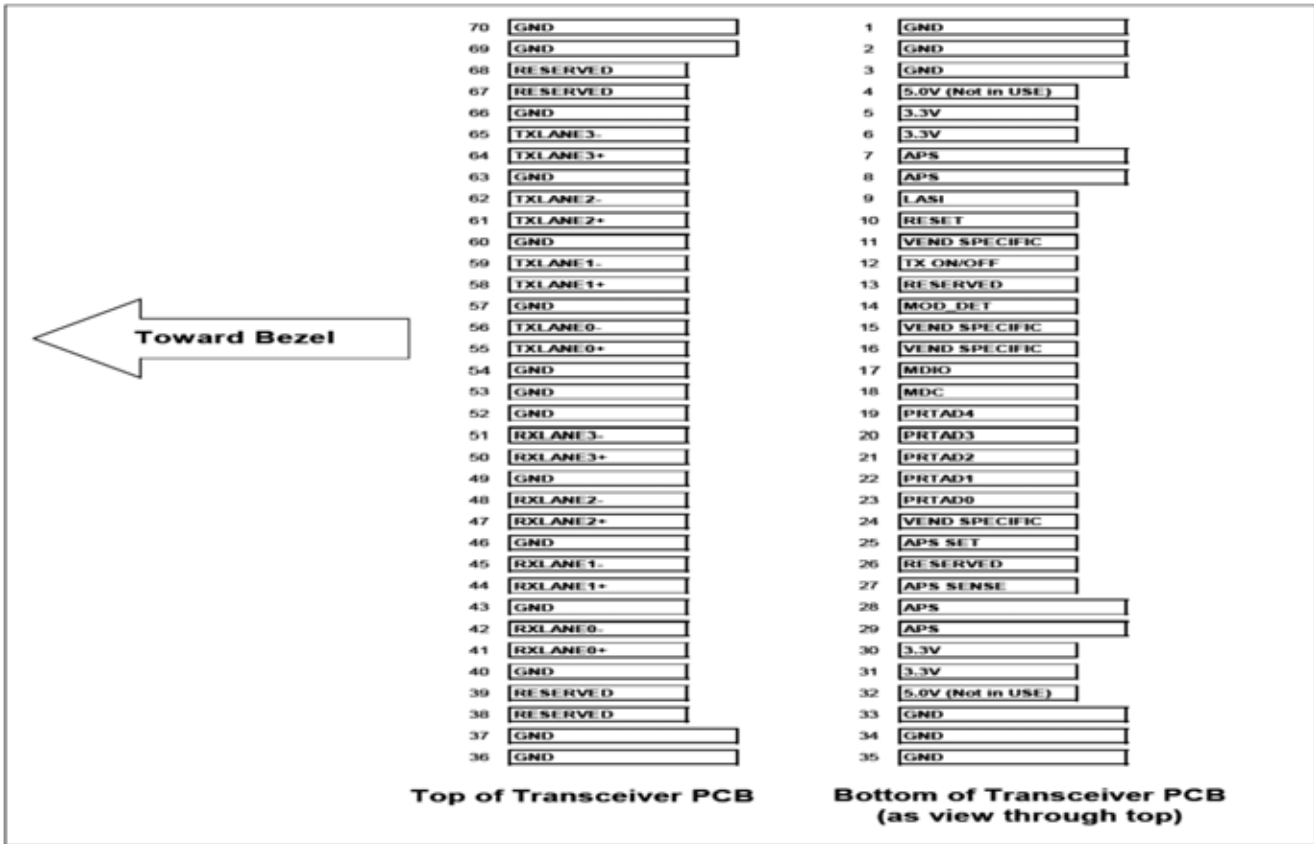



XENPAK 300m transceiver | 10G SR Ethernet

## PIN Functions

Pin #	Name - Description
1	Electrical Ground
2	Electrical Ground
3	Electrical Ground
4	Power
5	Power
6	Power
7	Adaptive Power Supply
8	Adaptive Power Supply
9	Link Alarm Status Interrupt, low active
10	Low active Reset Input 10K $\Omega$ pull-up on Transceiver
11	Vendor Specific Pin,. leave unconnected
12	High active Transmitter Enable Input 10K $\Omega$ pull-up on Transceiver
13	RESERVED
14	1k $\Omega$ to Ground On Transceiver
15	Vendor Specific Pin,. leave unconnected
16	Vendor Specific Pin,. leave unconnected
17	Management Data I/O. Requires external 10-22 k $\Omega$ pull-up to 1.2 V on host.
18	Management Clock Input
19	Port Address Bit 4(LOW=0)
20	Port Address Bit 3(LOW=0)
21	Port Address Bit 2(LOW=0)
22	Port Address Bit 1(LOW=0)
23	Port Address Bit 0(LOW=0)
24	Vendor Specific Pin,. leave unconnected
25	Feedback Input for APS, Input of APS Setting Resistor
26	RESERVED
27	APS Sense Output for APS Control Circuit
28	Adaptive Power Supply
29	Adaptive Power Supply
30	Power

## Mechanical Layouts

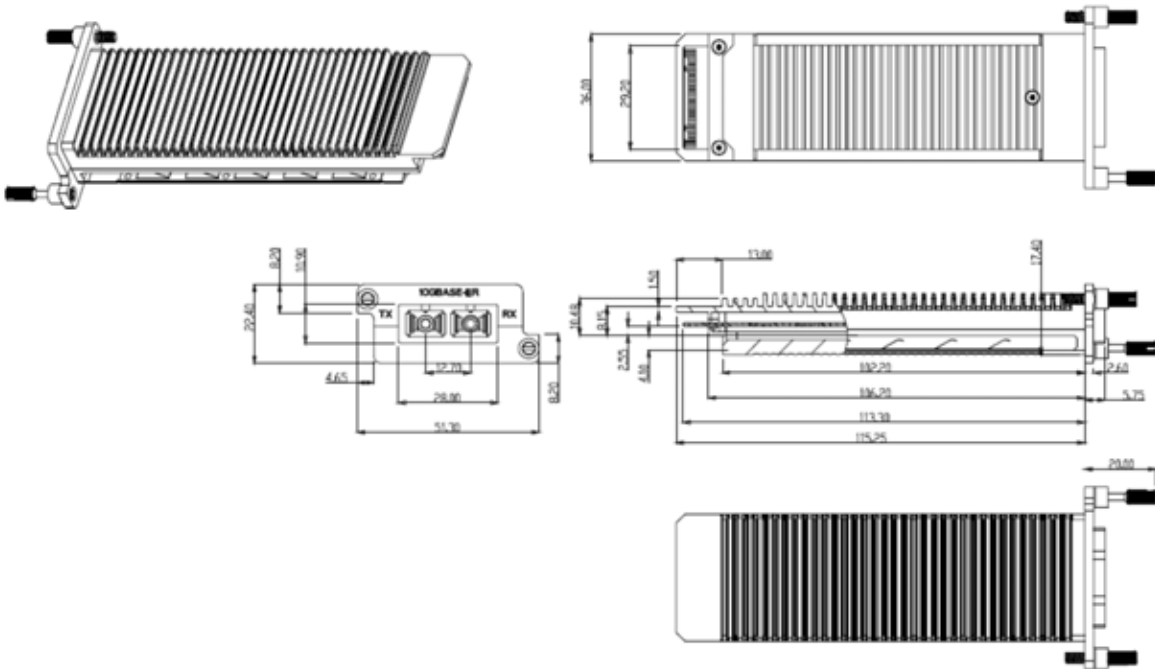
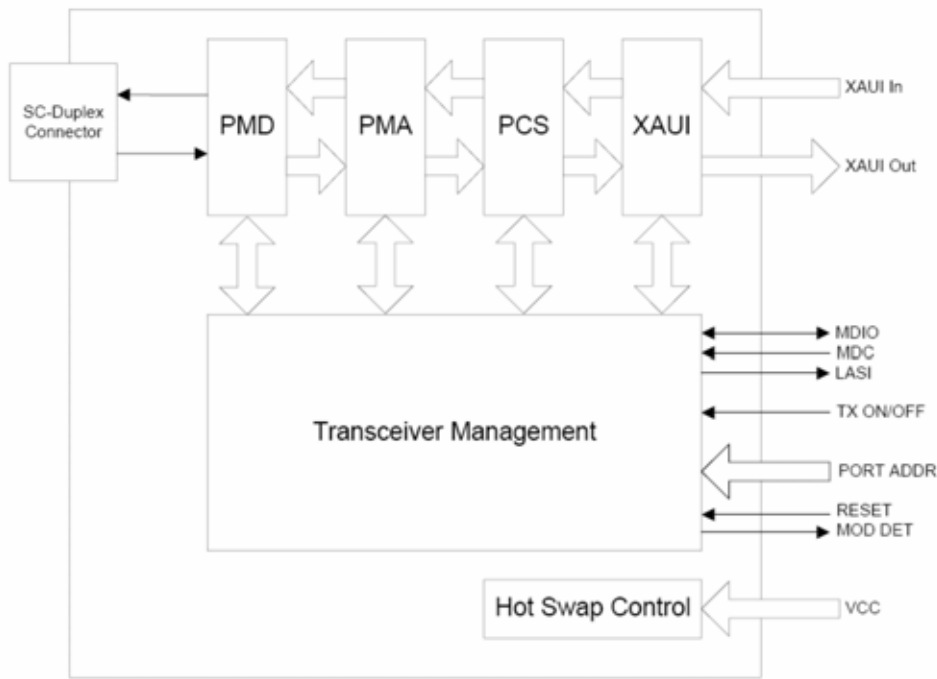

OptoSpan reserves the right to make changes or to discontinue any optical product or service without any notice. Applications and features described herein are for illustrative purposes only. OptoSpan makes no representation of warranty that such applications or features will be suitable for any specific use or compatibility without further testing or modifications. Not responsible for typographical errors.