

## Datasheet

### Tunable XFP Optical Transceiver Product Features

- SONET OC-192 / STM-64 w/ CDR 14dB Tunable XFP
- 40 km ER Tunable XFP for SMF @ 10Gbps
- 50GHz Monolithic MZM Laser 40 km Tunable XFP
- 0°C - 70°C Temperature - Extended/Industrial Available
- 2-Wire Interface Digital Diagnostic Monitoring (SFF-8724)
- Hot-swappable for Tunable XFP LC ports
- OptoSpan 1 year standard warranty
- Use with Finisar, Avago, JDSU & networks not requiring OEM compatibility
- XFP MSA, IEEE 802.3ae
- RoHS compliant

\* For OEM Compatibility, use Platinum Series Part# PXFT-10GXXXK040

### XFT-10G-K040XXX



### Applications

- 10Gb/s SONET/SDH
- 10Gb/s SONET/SDH w/FEC
- 10GbE & 10Gb/s FC
- 10GbE & 10Gb/s FC w/FEC

### Description

OptoSpan XFT-10G-K040XXX is a DWDM SONET OC-192 / STM-64 w/ CDR Tunable XFP transceiver designed for long distance optical communications up to 40 km with signaling rates up to 10Gbps.

OptoSpan 10Gb DWDM optical transceivers are compatible with many brands such as Finisar, Avago, JDSU and network environments that do not require any special compatibility. For networks that require special OEM compatibility, such as CISCO, BROCADE, JUNIPER, ALCATEL, HP, NORTEL, EMC, QLOGIC and other OEMs, consider OptoSpan Platinum OEM Series transceiver model# PXFT-10GXXXK040.

All OptoSpan long-reach Tunable XFP s are ROHS compliant, allow for real-time diagnostic monitoring as per SFF-8472 and designed to meet Multi-Source Agreement (MSA) standards for DWDM transceivers with LC interface.

### Optical Budget Calculation for 40 km Tunable XFP Optical Transceiver

XFT- 10G- K040XXX	Distance: 40 km				Fiber: 50GHz SMF	
	Tx Min dBm	Tx Max dBm	Rx Min dBm	Rx Max dBm	Link Attenuation dB	Power Budget dB
Product Specifications	-1	+3	-15	0		
Optical Calculation Results			-14.8	-10.8	13.8	14



**Tunable XFP DWDM 40 km transceiver | 10G ER SONET OC-192 / STM-64 w/ CDR**

**General Specifications**

Parameter	Unit	Min.	Typ.	Max
<b>Absolute Maximum Ratings</b>				
Maximum Supply Voltage	V	-0.5		6.0
Storage Temperature	°C	-40		+85
Case Operating Temperature	°C	-5		+70
<b>Recommended Operating Condition</b>				
Supply Voltage	V	4.75		5.25
Supply Current	mA			500
Data Rate	Gbps	8.5		11.35

**Electrical Characteristics**

Parameter	Unit	Min.	Typ.	Max
<b>Transmitter</b>				
Differential Input Voltage Swing	mVpp	120		820
Input Differential Impedance	ohm		100	
Transmit Disable Voltage - High	V	2.0		Vcc
Transmit Disable Voltage - Low	V	GND		GND+0.8
Transmit Fault Voltage - High	V			
Transmit Fault Voltage - Low	V			
<b>Receiver</b>				
Differential Output Voltage Swing	mVpp	340	650	850
Differential Output Impedance	ohms			
LOS Output Voltage - High	V	Vcc-0.5		VccHOST
LOS Output Voltage - Low	V	GND		GND+0.5



Tunable XFP DWDM 40 km transceiver | 10G ER SONET OC-192 / STM-64 w/ CDR

### Optical Characteristics

Parameter	Unit	Min.	Typ.	Max
<b>Transmitter</b>				
Output Optical Power	dBm	-1		+3
Optical Extinction Ratio	dB	8.2	9	
Optical Wavelength	nm	$\lambda-20$		$\lambda+20$
Spectral Width	nm			
Side Mode Suppression Ratio	dB			
<b>Receiver</b>				
Optical Center Wavelength	nm	1260		1620
Receiver Sensitivity @ 10.3	dBm	-15		0
LOS DE-Assert	dBm			-17
LOS Assert	dBm	-29		

### Laser Safety

This is a class 1 Laser Product according to IEC 60825-1:1993:+A1:1997+A2:2001. This product complies with 21 CFR 1040.10 and 1040 except for deviations pursuant to Laser Notice No. 50, dated July 26, 2001.

## Tunable XFP DWDM 40 km transceiver | 10G ER SONET OC-192 / STM-64 w/ CDR PIN Layout

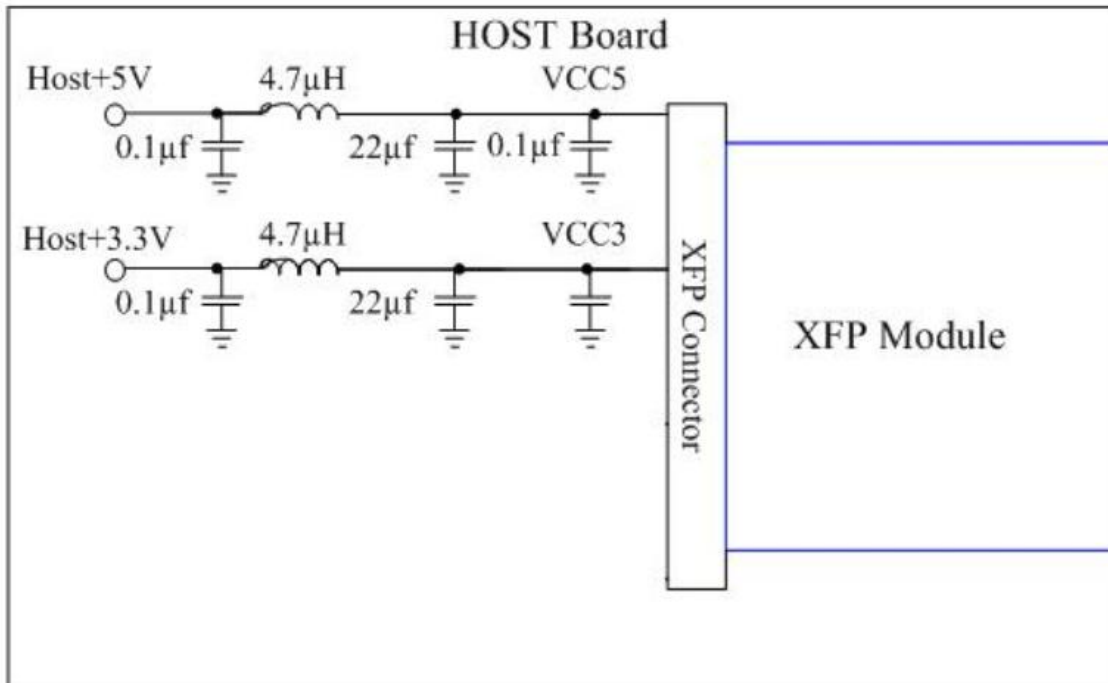
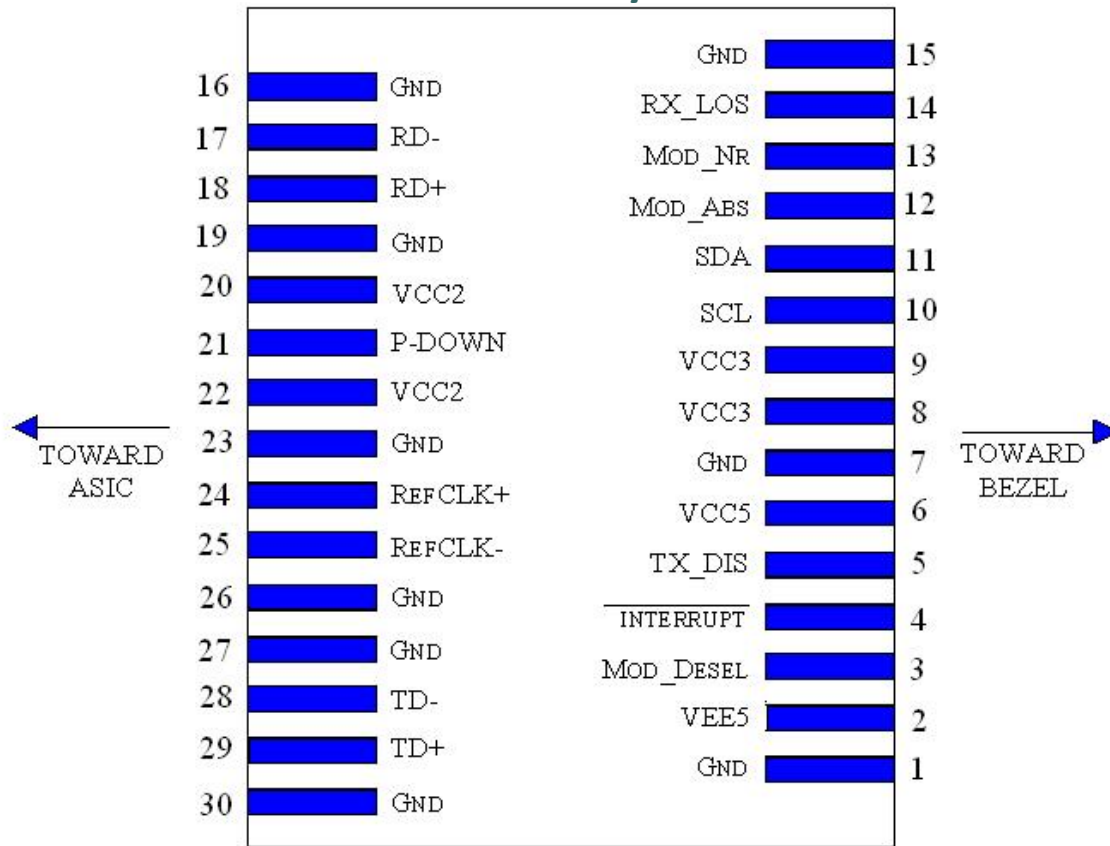



**Tunable XFP DWDM 40 km transceiver | 10G ER SONET OC-192 / STM-64 w/ CDR**  
**PIN Functions**

Pin #	Name - Description
1	Module Ground
2	Optional -5.2 Power Supply – Not required
3	Module De-select
4	Interrupt (bar)
5	Transmitter Disable; Transmitter laser source turned off
6	+5 Power Supply
7	Module Ground
8	+3.3V Power Supply
9	+3.3V Power Supply
10	Serial 2-wire interface clock
11	Serial 2-wire interface data line
12	Module Absent; Indicates module is not present. Grounded in the module
13	Module Not Ready
14	Receiver Loss of Signal indicator
15	Module Ground
16	Module Ground
17	Receiver inverted data output
18	Receiver non-inverted data output
19	Module Ground
20	+1.8V Power Supply
21	Power Down; When high, places the module in the low power stand-by mode
22	+1.8V Power Supply
23	Module Ground
24	Reference Clock non-inverted input, AC coupled on the host board – Not required
25	Reference Clock inverted input, AC coupled on the host board – Not required
26	Module Ground
27	Module Ground
28	Transmitter inverted data input
29	Transmitter non-inverted data input
30	Module Ground

## Tunable XFP DWDM 40 km transceiver | 10G ER SONET OC-192 / STM-64 w/ CDR Mechanical Layouts

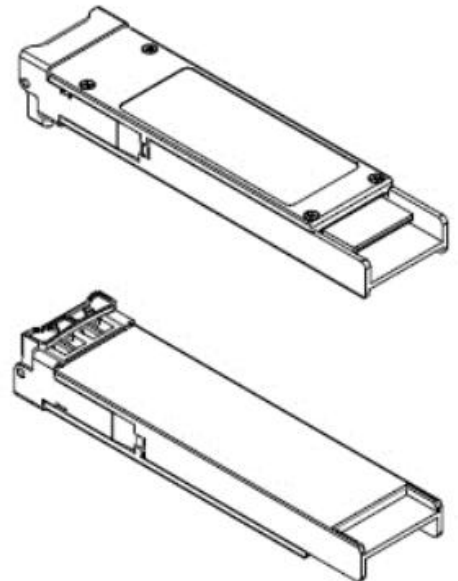
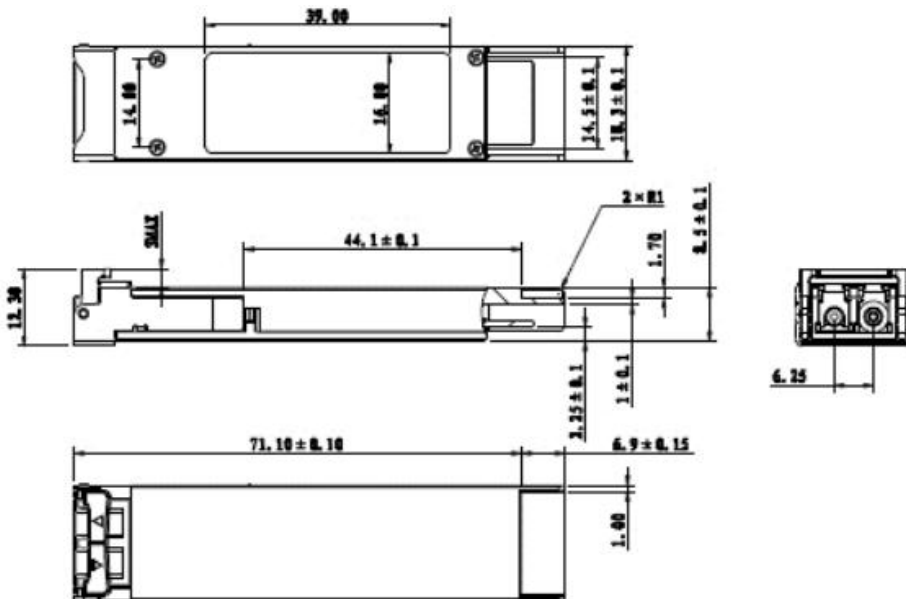
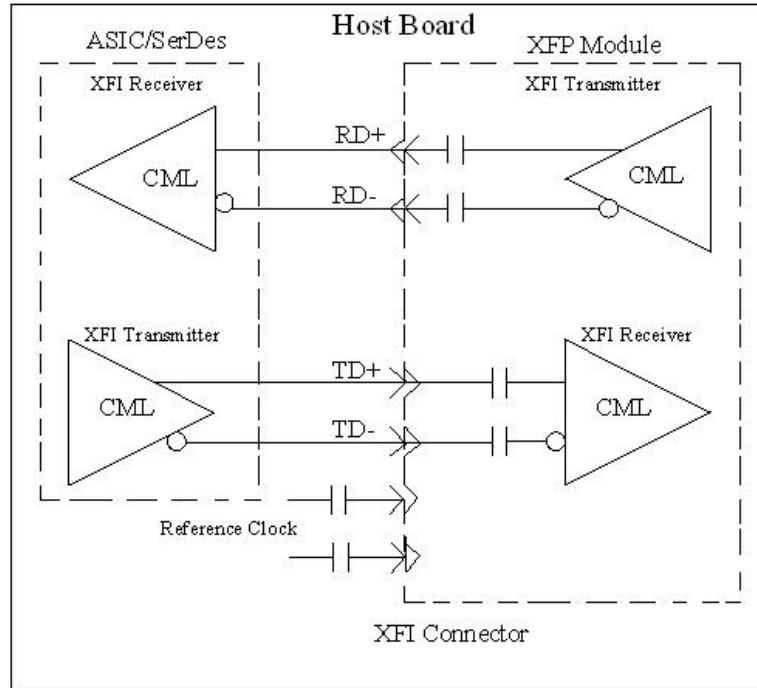

OptoSpan reserves the right to make changes or to discontinue any optical product or service without any notice. Applications and features described herein are for illustrative purposes only. OptoSpan makes no representation of warranty that such applications or features will be suitable for any specific use or compatibility without further testing or modifications. Not responsible for typographical errors.