

SFP+ 2 km transceiver | Cisco Compatible 10G LR Ethernet

Designed for OEM networks such as Cisco, HP, Juniper, Brocade, Alcatel etc.

Datasheet

SFP+ Optical Transceiver Product Features

- Exclusive Japanese OSAs for Ultimate Reliability
- 10GBASE-LR/LW Ethernet 8.4dB SFP+
- 2 km LR SFP+ for SMF @ 10Gbps
- 1310nm FP+PIN Laser 2 km SFP+
- 0°C - 70°C Temperature - Extended/Industrial Available
- 2-Wire Interface Digital Diagnostic Monitoring (SFF-8724)
- Hot-swappable for SFP+ LC ports
- Extended 2 Years Warranty
- Tested and Certified in Brand Specific Networks and Target Applications
- Assembled Using Highest Quality Raw Components
- Compliant with SFF-8431, SFF-8432 & ROHS

PSPP-81DT31K002



Applications

- 10GBASE-SR @ 10.31Gbps
- 10 Gigabit Ethernet
- Fibre Channel 8x
- Fibre Channel 4x

Description

Platinum OEM Series PSPP-81DT31K002 is a Cisco Compatible Duplex 10GBASE-LR/LW Ethernet 10G Ethernet / 8G FC SFP+ transceiver designed for long distance optical communications up to 2 km with signaling rates up to 10Gbps.

OptoSpan Platinum OEM Series 10Gbps Duplex optical transceivers have undergone rigorous qualification and certification testing to provide End-to-End Compatibility using switching equipment from CISCO, BROCADE, JUNIPER, ALCATEL, HP (select models), NORTEL, EMC, QLOGIC and other OEMs.

All OptoSpan Platinum OEM Series long-reach SFP+ s are ROHS compliant, allow for real-time diagnostic monitoring as per SFF-8472 and designed to meet Multi-Source Agreement (MSA) standards for Duplex transceivers with LC interface.

Optical Budget Calculation for 2 km Platinum OEM SFP+ Optical Transceiver

PSPP-81DT31K002	Distance: 2 km				Fiber: 1310nm SMF	
	Tx Min dBm	Tx Max dBm	Rx Min dBm	Rx Max dBm	Link Attenuation dB	Power Budget dB
Product Specifications	-6	-1	-14.4	0.5		
Optical Calculation Results			-7.1	-1.9	1.9	8.4

SFP+ 2 km transceiver | Cisco Compatible 10G LR Ethernet

General Specifications

Parameter	Unit	Min.	Typ.	Max
Absolute Maximum Ratings				
Maximum Supply Voltage	V	-0.5		3.6
Storage Temperature	°C	-40		+85
Case Operating Temperature	°C	-5		+70
Recommended Operating Condition				
Supply Voltage	V	3.15	3.3	3.45
Supply Current	mA			300
Data Rate	Gbps		10.31	

Electrical Characteristics

Parameter	Unit	Min.	Typ.	Max
Transmitter				
Differential Input Voltage Swing	mVpp	150		1200
Input Differential Impedance	ohm	85	100	115
Transmit Disable Voltage - High	V	2		3.45
Transmit Disable Voltage - Low	V	0		0.8
Transmit Fault Voltage - High	V	2		Vcc+0.3
Transmit Fault Voltage - Low	V	0		0.5
Receiver				
Differential Output Voltage Swing	mVpp	350		700
Differential Output Impedance	ohms	90	100	110
LOS Output Voltage - High	V	2		Vcc+0.3
LOS Output Voltage - Low	V	0		0.8

SFP+ 2 km transceiver | Cisco Compatible 10G LR Ethernet

Optical Characteristics

Parameter	Unit	Min.	Typ.	Max
Transmitter				
Output Optical Power	dBm	-6		-1
Optical Extinction Ratio	dB	3.5		
Optical Wavelength	nm	1270	1310	1355
Spectral Width	nm			3
Side Mode Suppression Ratio	dB	30		
Receiver				
Optical Center Wavelength	nm	1260		1565
Receiver Sensitivity @ 10.31Gbp	dBm	-14.4		0.5
LOS DE-Assert	dBm			-15
LOS Assert	dBm	-25		

Laser Safety

This is a class 1 Laser Product according to IEC 60825-1:1993:+A1:1997+A2:2001. This product complies with 21 CFR 1040.10 and 1040 except for deviations pursuant to Laser Notice No. 50, dated July 26, 2001.

SFP+ 2 km transceiver | Cisco Compatible 10G LR Ethernet
PIN Layout

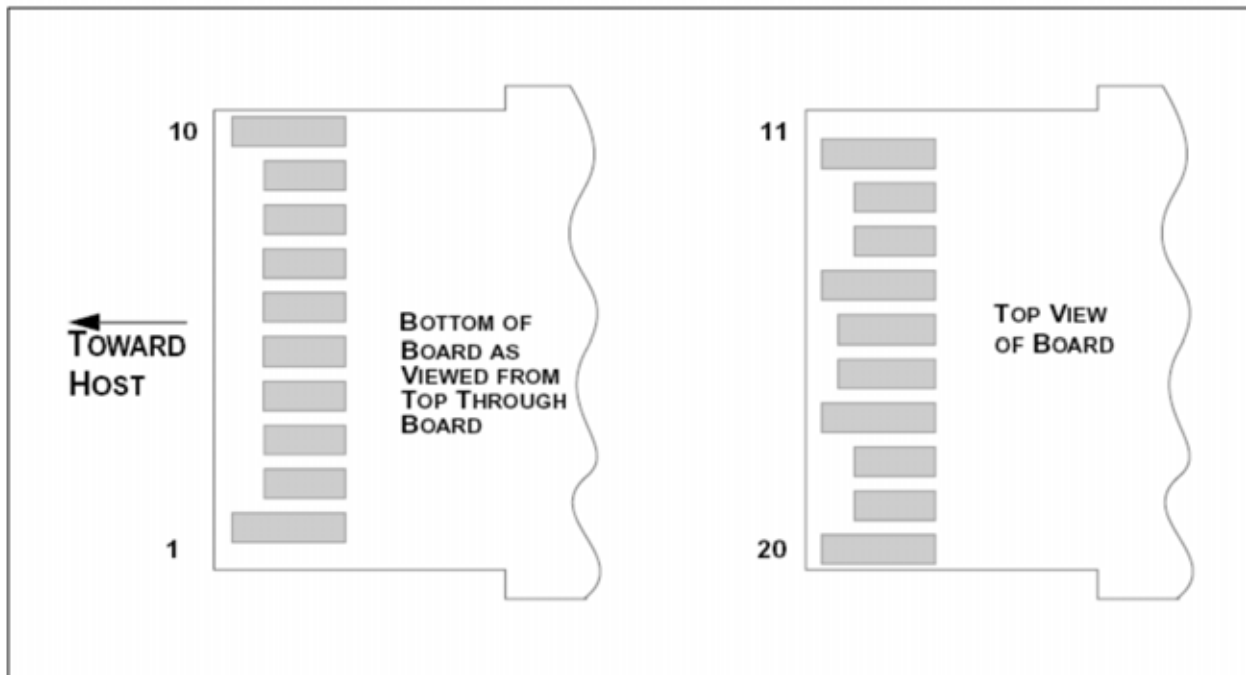
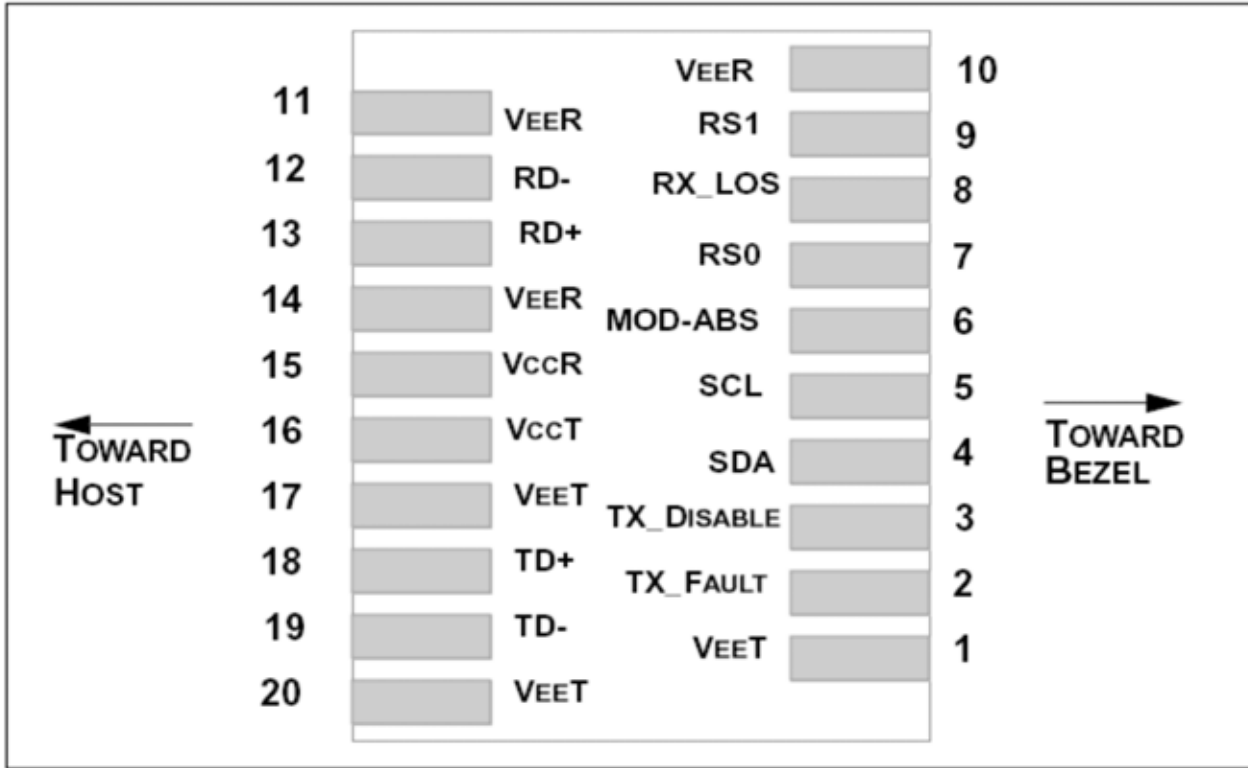

SFP+ 2 km transceiver | Cisco Compatible 10G LR Ethernet
PIN Functions

Pin #	Name - Description
1	Transmitter Ground
2	Transmitter Fault Indication
3	Transmitter Disable
4	Module Definition 2
5	Module Definition 1
6	Module Definition 0
7	RX Rate Select (LVTTL)
8	Loss of Signal
9	TX Rate Select (LVTTL)
10	Receiver Ground
11	Receiver Ground
12	Inv. Received Data out
13	Received Data Out
14	Receiver Ground
15	Receiver Power
16	Transmitter Power
17	Transmitter Ground
18	Transmit Data In
19	Inv. Transmit Data In
20	Transmitter Ground
21	
22	
23	
24	
25	
26	
27	
28	
29	
30	

SFP+ 2 km transceiver | Cisco Compatible 10G LR Ethernet Mechanical Layouts

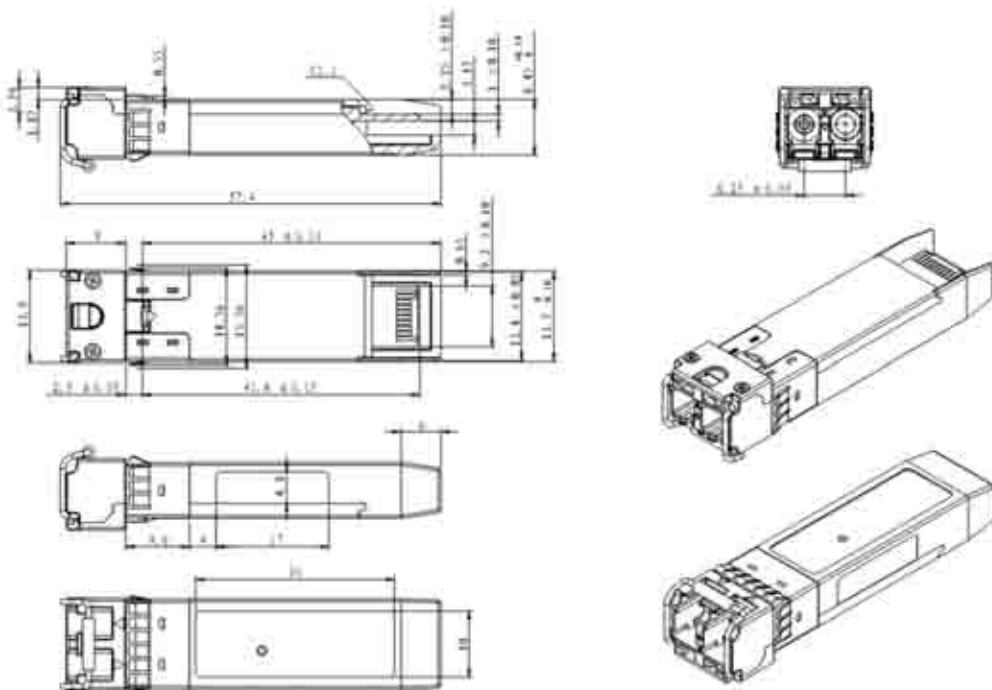
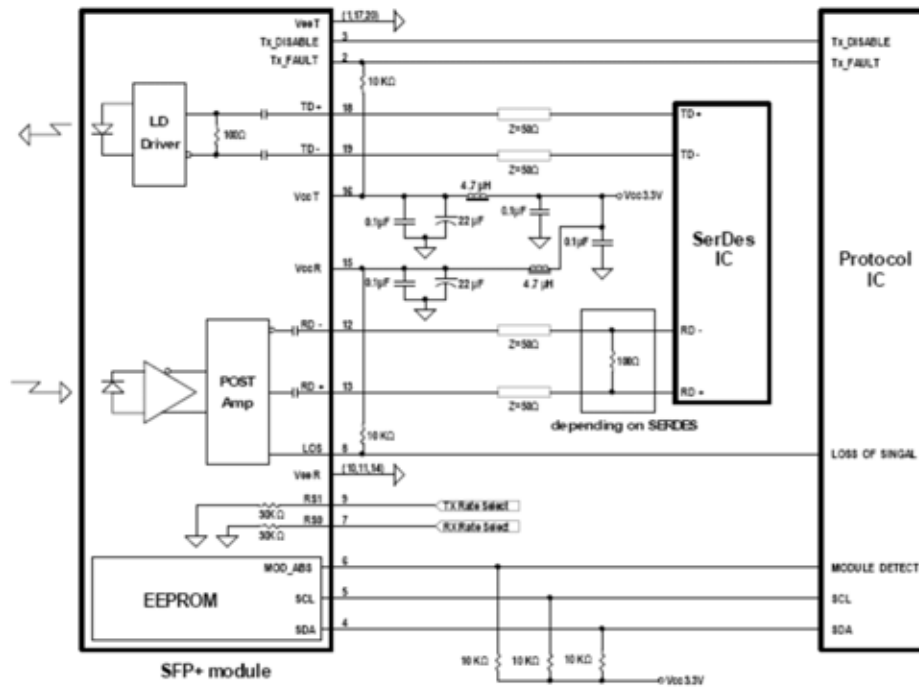

OptoSpan reserves the right to make changes or to discontinue any optical product or service without any notice. Applications and features described herein are for illustrative purposes only. OptoSpan makes no representation of warranty that such applications or features will be suitable for any specific use or compatibility without further testing or modifications. Not responsible for typographical errors.