

**SFP+ SONET/SDH 2 km transceiver | Cisco Compatible 10G SR SONET OC-192 / STM-64 w/ CDR**  
**Designed for OEM networks such as Cisco, HP, Juniper, Brocade, Alcatel etc.**

### Datasheet

## SONET/SDH SFP+ Optical Transceiver

### Product Features

- Exclusive Japanese OSAs for Ultimate Reliability
- SONET OC-192 / STM-64 w/ CDR 8.4dB SONET/SDH SFP+
- 2 km SR SONET/SDH SFP+ for SMF @ 10Gbps
- 1310nm FP+PIN Laser 2 km SONET/SDH SFP+
- 0°C - 70°C Temperature - Extended/Industrial Available
- 2-Wire Interface Digital Diagnostic Monitoring (SFF-8724)
- Hot-swappable for SONET/SDH SFP+ LC ports
- Extended 2 Years Warranty
- Tested and Certified in Brand Specific Networks and Target Applications
- Assembled Using Highest Quality Raw Components
- Compliant with SFF-8431, SFF-8432 & ROHS

## PSPS-81DT31K002



### Applications

- SONET OC-192 / SDH STM-64
- OTN ITU-T G.709
- 10GBASE-SR @ 10.31Gbps
- 10GbE & 10Gb/s FC w/FEC

## Description

Platinum OEM Series PSPS-81DT31K002 is a Cisco Compatible Duplex SONET OC-192 / STM-64 w/ CDR SONET/SDH SFP+ with CDR, FEC & OTN G.709 transceiver designed for long distance optical communications up to 2 km with signaling rates up to 10Gbps.

OptoSpan Platinum OEM Series 10Gbps Duplex optical transceivers have undergone rigorous qualification and certification testing to provide End-to-End Compatibility using switching equipment from CISCO, BROCADE, JUNIPER, ALCATEL, HP (select models), NORTEL, EMC, QLOGIC and other OEMs.

All OptoSpan Platinum OEM Series long-reach SONET/SDH SFP+ s are ROHS compliant, allow for real-time diagnostic monitoring as per SFF-8472 and designed to meet Multi-Source Agreement (MSA) standards for Duplex transceivers with LC interface.

### Optical Budget Calculation for 2 km Platinum OEM SONET/SDH SFP+ Optical Transceiver

PSPS-81DT31K002	Distance: 2 km				Fiber: 1310nm SMF	
	Tx Min dBm	Tx Max dBm	Rx Min dBm	Rx Max dBm	Link Attenuation dB	Power Budget dB
Product Specifications	-6	-1	-14.4	0.5		
Optical Calculation Results			-7.1	-1.9	1.9	8.4

SFP+ SONET/SDH 2 km transceiver | Cisco Compatible 10G SR SONET OC-192 / STM-64 w/ CDR

## General Specifications

Parameter	Unit	Min.	Typ.	Max
<b>Absolute Maximum Ratings</b>				
Maximum Supply Voltage	V	-0.5		3.6
Storage Temperature	°C	-40		+85
Case Operating Temperature	°C	-5		+70
<b>Recommended Operating Condition</b>				
Supply Voltage	V	3.15	3.3	3.45
Supply Current	mA			300
Data Rate	Gbps		10.31	

## Electrical Characteristics

Parameter	Unit	Min.	Typ.	Max
<b>Transmitter</b>				
Differential Input Voltage Swing	mVpp	150		1200
Input Differential Impedance	ohm	85	100	115
Transmit Disable Voltage - High	V	2		3.45
Transmit Disable Voltage - Low	V	0		0.8
Transmit Fault Voltage - High	V	2		Vcc+0.3
Transmit Fault Voltage - Low	V	0		0.5
<b>Receiver</b>				
Differential Output Voltage Swing	mVpp	350		700
Differential Output Impedance	ohms	90	100	110
LOS Output Voltage - High	V	2		Vcc+0.3
LOS Output Voltage - Low	V	0		0.8

## Optical Characteristics

Parameter	Unit	Min.	Typ.	Max
<b>Transmitter</b>				
Output Optical Power	dBm	-6		-1
Optical Extinction Ratio	dB	3.5		
Optical Wavelength	nm	1270	1310	1355
Spectral Width	nm			3
Side Mode Suppression Ratio	dB	30		
<b>Receiver</b>				
Optical Center Wavelength	nm	1260		1565
Receiver Sensitivity @	dBm	-14.4		0.5
LOS DE-Assert	dBm			-15
LOS Assert	dBm	-25		

## Laser Safety

This is a class 1 Laser Product according to IEC 60825-1:1993:+A1:1997+A2:2001. This product complies with 21 CFR 1040.10 and 1040 except for deviations pursuant to Laser Notice No. 50, dated July 26, 2001.

SFP+ SONET/SDH 2 km transceiver | Cisco Compatible 10G SR SONET OC-192 / STM-64 w/ CDR  
**PIN Layout**

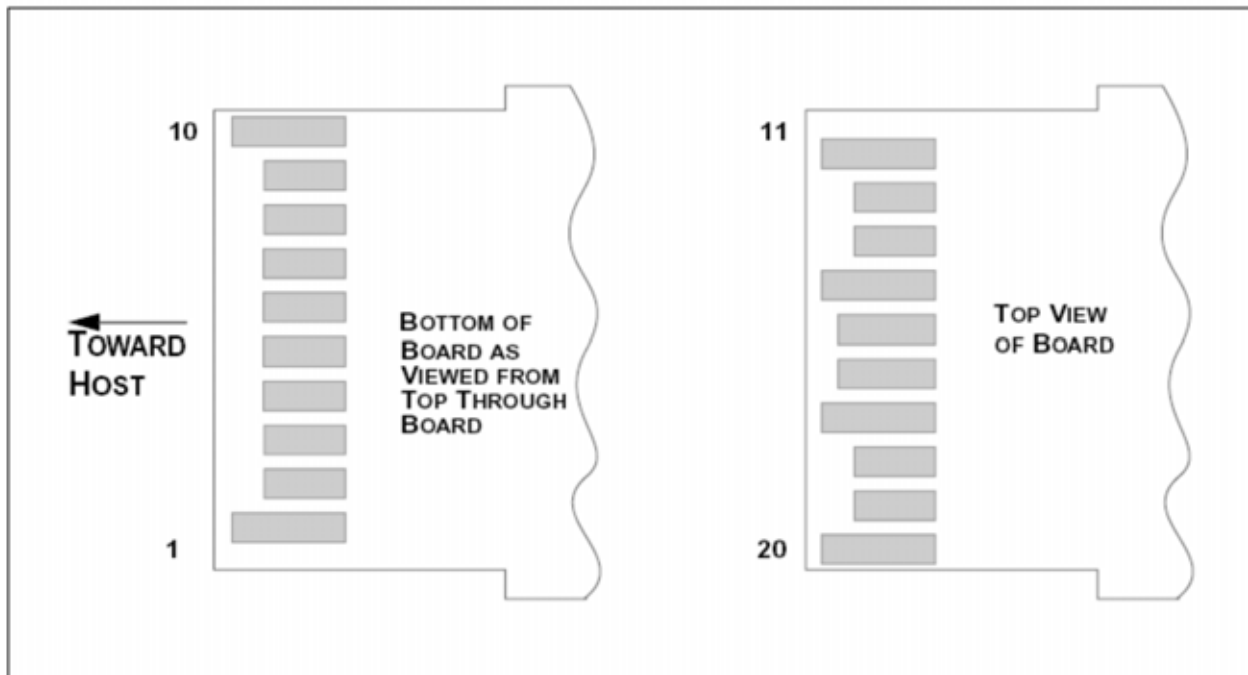
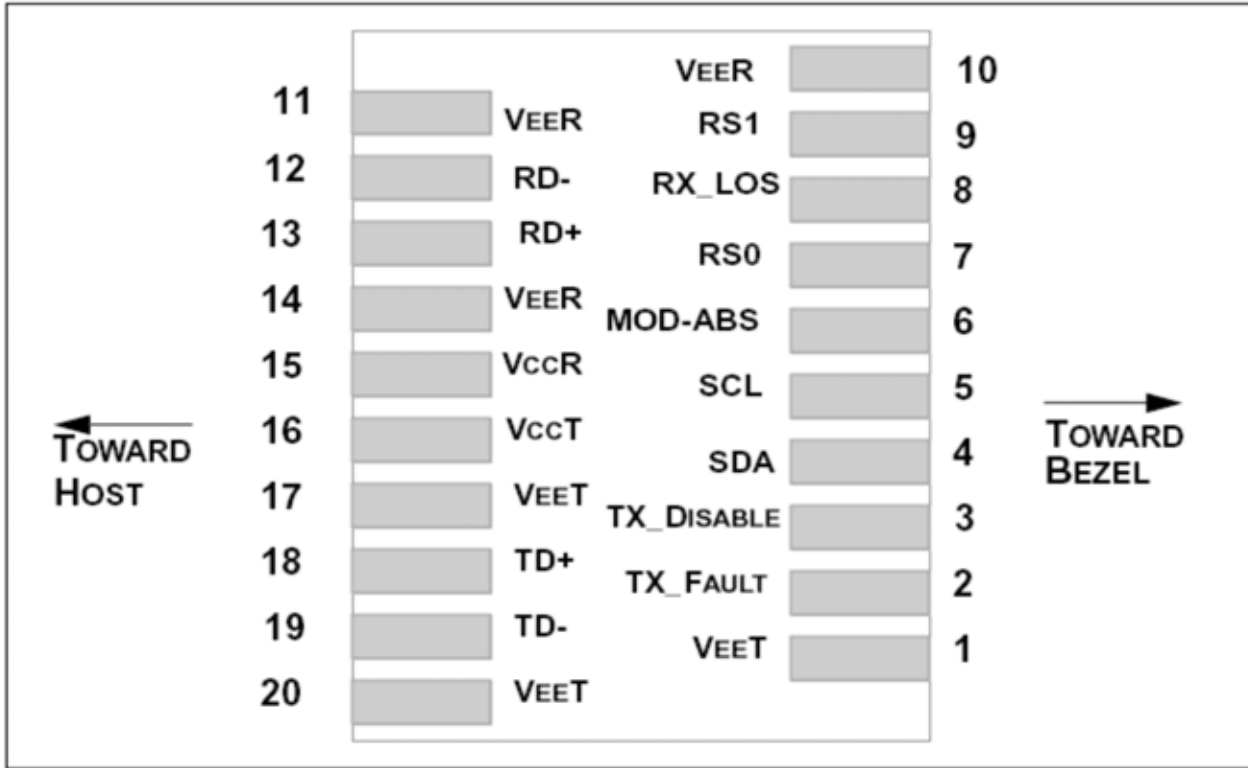

SFP+ SONET/SDH 2 km transceiver | Cisco Compatible 10G SR SONET OC-192 / STM-64 w/ CDR  
**PIN Functions**

Pin #	Name - Description
1	Transmitter Ground
2	Transmitter Fault Indication
3	Transmitter Disable
4	Module Definition 2
5	Module Definition 1
6	Module Definition 0
7	RX Rate Select (LVTTL)
8	Loss of Signal
9	TX Rate Select (LVTTL)
10	Receiver Ground
11	Receiver Ground
12	Inv. Received Data out
13	Received Data Out
14	Receiver Ground
15	Receiver Power
16	Transmitter Power
17	Transmitter Ground
18	Transmit Data In
19	Inv. Transmit Data In
20	Transmitter Ground
21	
22	
23	
24	
25	
26	
27	
28	
29	
30	

### SFP+ SONET/SDH 2 km transceiver | Cisco Compatible 10G SR SONET OC-192 / STM-64 w/ CDR

### Mechanical Layouts

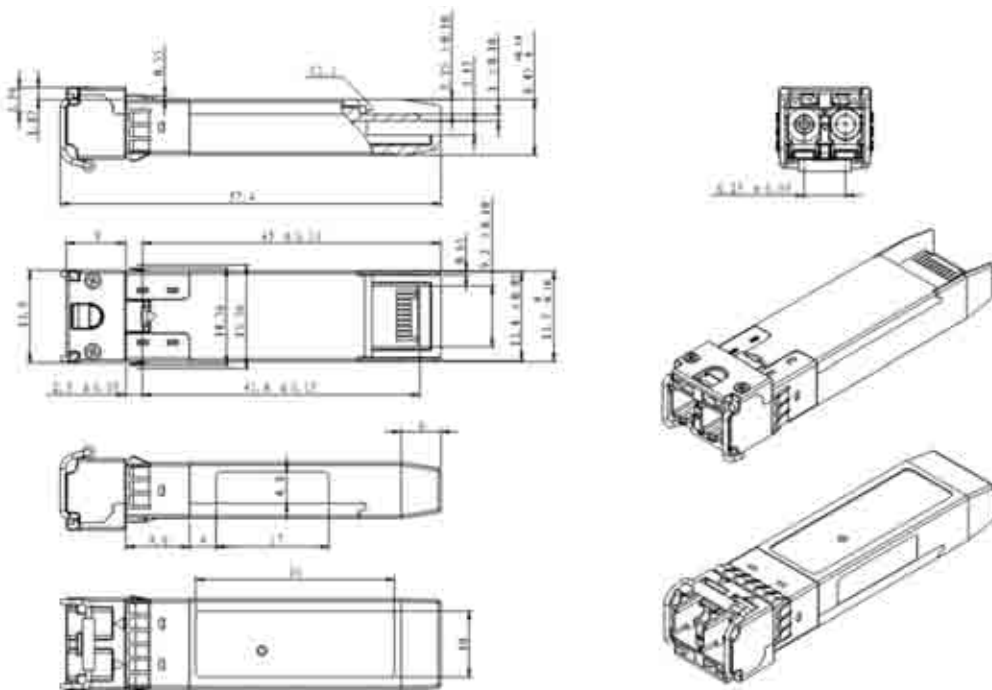
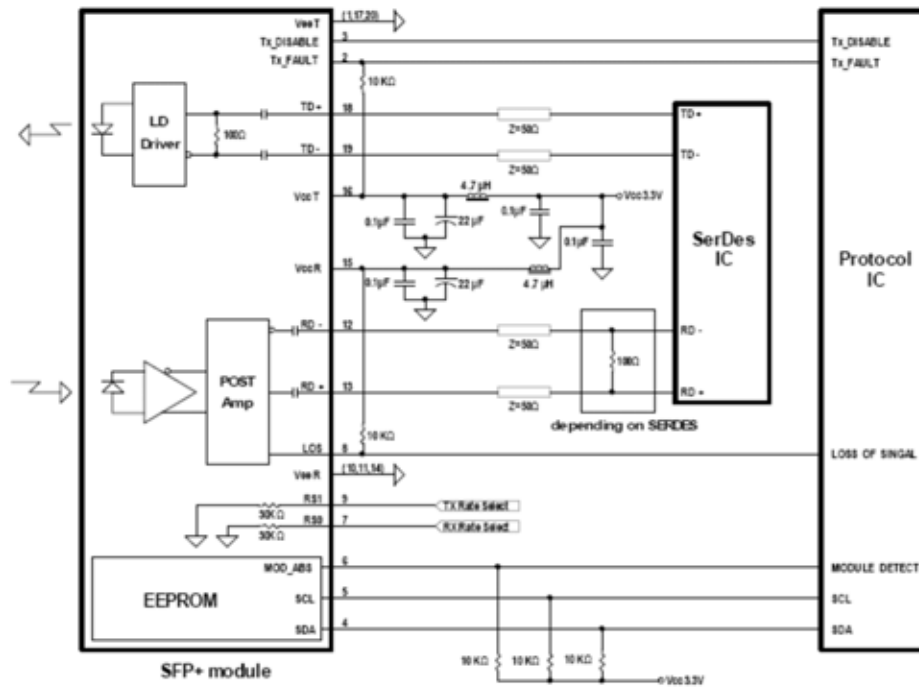

OptoSpan reserves the right to make changes or to discontinue any optical product or service without any notice. Applications and features described herein are for illustrative purposes only. OptoSpan makes no representation of warranty that such applications or features will be suitable for any specific use or compatibility without further testing or modifications. Not responsible for typographical errors.